



Features

- Ideal server form factor optimizes, space, efficiency, and load variations
- High efficiency maximized between 30-80% load conditions
- Unconditionally stable under any load condition
- Wide range DC-input model available (SFD550-12BG)
- Wide input voltage range (90-264 VAC) with PFC
- 1U or 2U height configurations
- Active current share with ORing FET
- I²C interface status monitoring
- Standby voltage of 3.3 VDC @ 3 A
- Overtemperature, overload, and overvoltage protection
- Status LEDs: AC OK, POWER GOOD, PS FAIL

Applications

- Datacom
- Distributed power systems

Description

The SFP650-12BG is a 650-watt, power factor corrected (PFC) front-end which provides a 12 VDC output for datacom and other distributed power applications. Its compact size enables mounting in both 1U and 2U height racks. High efficiencies, advanced thermal management techniques, and an internal fan increase reliability over a broad range of operating conditions. Internal ORing diodes facilitate use in hot-swap (plug)¹, redundant configurations.

Status is provided with front panel LEDs, logic signals, and via the I²C management interface bus.

The SFP650-12BG meets international safety requirements and is CE marked to the Low Voltage Directive (LVD).

Model Selection

Model	Nominal Output Voltage (VDC)	Adjustment Range (VDC)	Maximum Output Current (Amps)	Regulation %	Ripple & Noise @ 20 MHz BW (mV)
SFP650-12BG	12 3.3 (Standby)	N/A N/A	53.3 3	±3 ±3	100 100

¹ Proper hot-swap (plug) operation instruction: Power supply is not intended to be inserted into the system with AC cord already applied. Alternatively, if there is an application where power supply insertion with AC cord is required; PS_ON must be toggled or AC recycled after insertion into the system to reset the power supply.

Input Specifications

Parameter	Conditions/Description	Min.	Nom.	Max.	Units
AC Input Voltage	Single-phase continuous input range.	90		264	VAC
Input Frequency	AC input.	47		63	Hz
Hold-up Time	After last AC line peak at full power. At 115 VAC.	14			ms
Input Current	At full-rated load. At 90 VAC.			9	A rms
Inrush Surge Current	Excluding Xcap. Vin = 264 VAC. 25 °C			15	A pk
Power Factor	Per EN61000-3-2	> 0.95			W/VA

Output Specifications

Parameter	Conditions/Description	Min.	Nom.	Max.	Units
Efficiency NOTE: Internal fan is considered part of the load as it is driven from the 12V output; Vaux load is set to 0A for efficiency measurements.	With Vin at 115VAC and 50% to 75% load on V1.	86.0			%
	With Vin at 115VAC and 75% to 100% load on V1.	86.0			%
	With Vin at 230VAC and 50% to 75% load on V1.	87.0			%
	With Vin at 230VAC and 75% to 100% load on V1.	89.0			%
Minimum Load	Minimum loading required to maintain regulation.	0			A
Output Power				650	W
Overshoot	Output voltage overshoot at turn-on.			< 5	%
Transient Response	Maximum recovery time to within 1% of initial set point due to a 25% load change, 1A/μs. 12V output: Standby output:			5	ms
				5	ms
	Maximum deviation: 12V output: Standby output:			3	%
				3	%
Turn-On Delay with PS_ON signal	Time required for initial output voltage stabilization after application of AC input or ON/OFF signal.			1500	ms
Output Regulation	See Model Selection data on page 1.				

Interface Signals and Internal Protection¹

Parameter	Conditions/Description	Min.	Nom.	Max.	Units
Overvoltage Protection	Latch-style overvoltage protection.			15 4.3	V
Overcurrent Protection	Current limit (Latching Mode). 12V output: Standby output:	56.0 3.2		69.3 6	A
Short-Circuit Protection	Latching Mode.				
Overtemperature/ Fan Failure Warning	12V output will shut down in the event of an overtemperature condition or blocked fan rotor. OT setpoint is 62 ±3 °C. Supply's fan and Vaux are active. Power supply will recover when OT condition is removed. Amber OT LED will turn ON to indicate fault condition.				
PS_KILL	Output enable. Pulled low on conjunction with PS_ON being pulled low allows V1 to be activated. PSKILL will cause the PSU to latch off the 12V rail, the latch can be cleared by recycling PSON or recycling the AC supply.				
+12V Current Share	0 to 8V signal used for active current sharing.				
Write Protect	For factory use only.				
PS A0	I ² C Address.				
SDA	I ² C Data line (3.3V).				
SCL	I ² C Clock line (3.3V).				
Tach	Two pulses per fan revolution.				
AC_OK/H	High signal indicates AC is within PSU limits.				
Present/L	100 Ohm resistor internally connected to RTN allowing the PSU to be detected on insertion.				
Alert/L	Low signal indicates PSU fan is running below speed or an overtemperature limit was exceeded.				
PWROK/H	High signal indicates both outputs are within regulation limits.				

¹ Refer to product specification for internal pull up impedances and timing of these signals.

I²C Bus Management Interface¹

Static	Includes static information such as: part number and revision level, output rating, serial number, date code, and manufacturing location.
Status (Logic 1 or 0)	AC Input OK. DC Output OK. Overtemperature. Overcurrent. Fan OK. Overvoltage Alert Undervoltage Alert
Real-Time Monitoring	Output voltage (main output). LSB = 20 mV Output current (main output). LSB = 100 mA

¹ Reference "I²C Management Interface" and "EEPROM Table of Contents" documents for SFP650-12BG (consult factory).

Safety, Regulatory, and EMI Specifications

Parameter	Conditions/Description	Min.	Nom.	Max.	Units
Agency Approvals	UL 60950-1, CSA C22.2 No. 60950-1, EN 60950-1 (TÜV), CE Mark for LVD.				
Electromagnetic Interference	FCC CFR title 47 Part 15 Sub-Part B, EN55022/CISPR 22.	Conducted: A Radiated: A			Class
Harmonics	Per IEC61000-3-2.	A			Class
Voltage Fluctuation and Flicker	Per IEC61000-3-3.	Pass			
ESD Susceptibility	Per EN 61000-4-2, Level 4., Contact Discharge: Performance criteria A Air Discharge:	±8 ±15		.	kV
Radiated Susceptibility	Per EN 61000-4-3, Level 3., Performance criteria A	10		.	V/M
EFT/Burst	Per EN 61000-4-4, Level 4. Performance criteria A	±4		.	kV
Input Transient Protection	Per EN 61000-4-5, Class 3., Performance criteria A Line-to-Line: Line-to-Ground:	1 2		.	kV
RF Conducted Disturbances	Per EN 61000-4-6, Level 2., Performance criteria A	3		.	V
Voltage Interruptions	Per EN 61000-4-11, performance criterion B 30%. Per EN 61000-4-11, performance criterion C 60%. Per EN 61000-4-11, performance criterion C 95%.	10 100 5		.	ms ms Sec
Voltage Sag Immunity	Per SEMI F47-0999 > 100 VAC. No output voltage interruption.			.	
Leakage Current	Per EN60950. At 240 VAC:			1.75	mA

Environmental Specifications

Parameter	Conditions/Description	Min.	Nom.	Max.	Units
Altitude	Operating. Non-Operating.			10K 40K	ASL ft ASL ft
Operating Temperature	Internal DC fan for cooling. At 100% load:	0		50	°C
Storage Temperature		-40		85	°C
Temperature Coefficient	0 °C to 45 °C (after 15-minute warm-up).			0.02	%/°C
Relative Humidity	Non-condensing.			95	%RH
Shock	Operating: half-sine, 11 ms, 3-axis.			±10	Gpk
Vibration	Operating: swept sine 5-500 Hz.			2	Gpk
	Non-operating: random 10-2000 Hz.			6.15	Grms

Reliability

Parameter	Conditions/Description	Min.	Nom.	Max.	Units
MTBF	(Calculated) MILHDBK 217F Ground Benign. Demonstrated. Useful Life.	100 000 200 000 10			hrs hrs yrs

LED Indicators

Indicator	LED Color
POWER GOOD	GREEN
AC OK	GREEN
PS FAIL	AMBER

Mechanical Drawings

Weight: 1.46 kg (3.22 lb)

FRONT VIEW

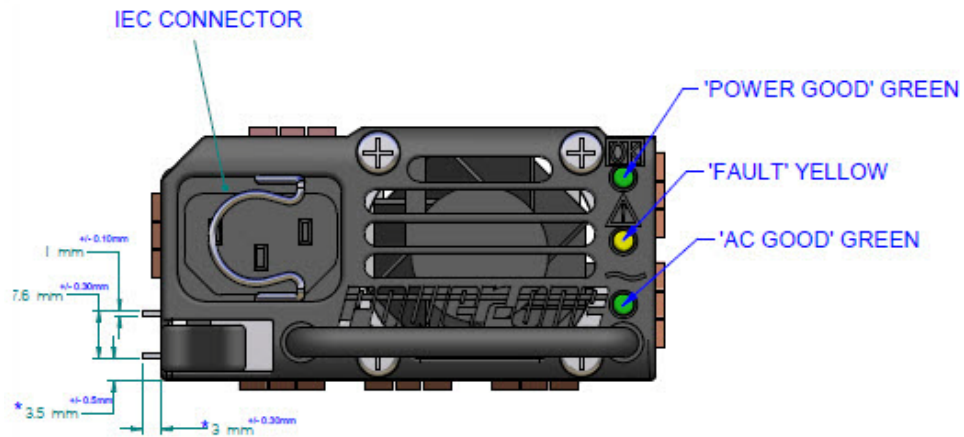

* DENOTES CRITICAL DIMENSIONS.

BACK VIEW

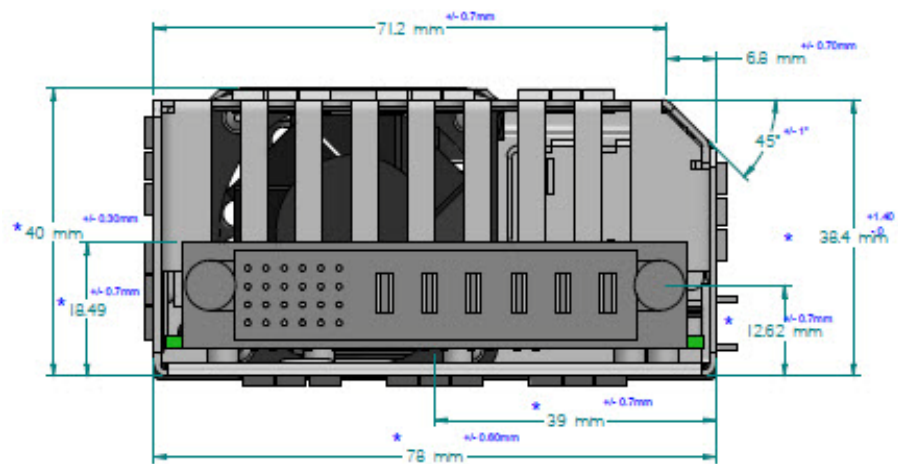

TOP VIEW

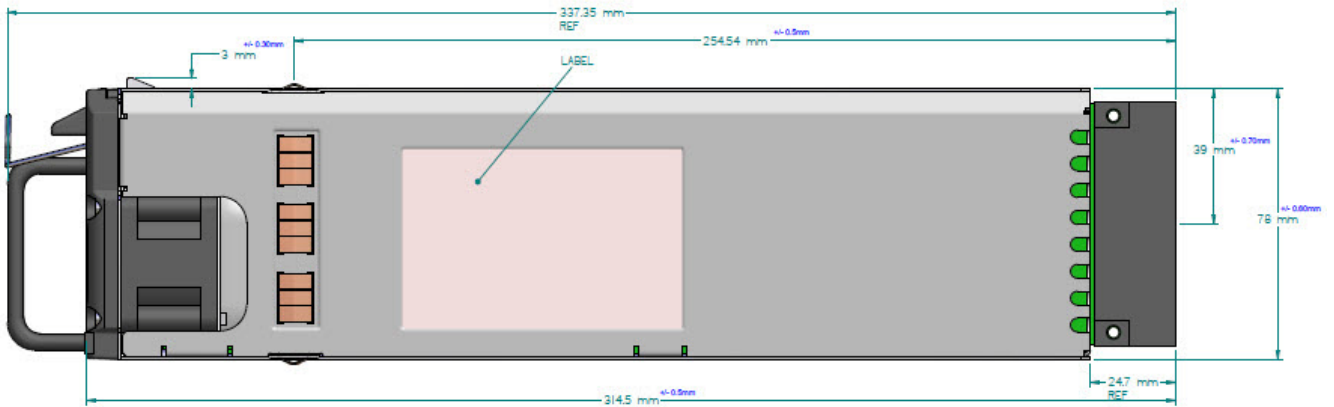

SIDE VIEW

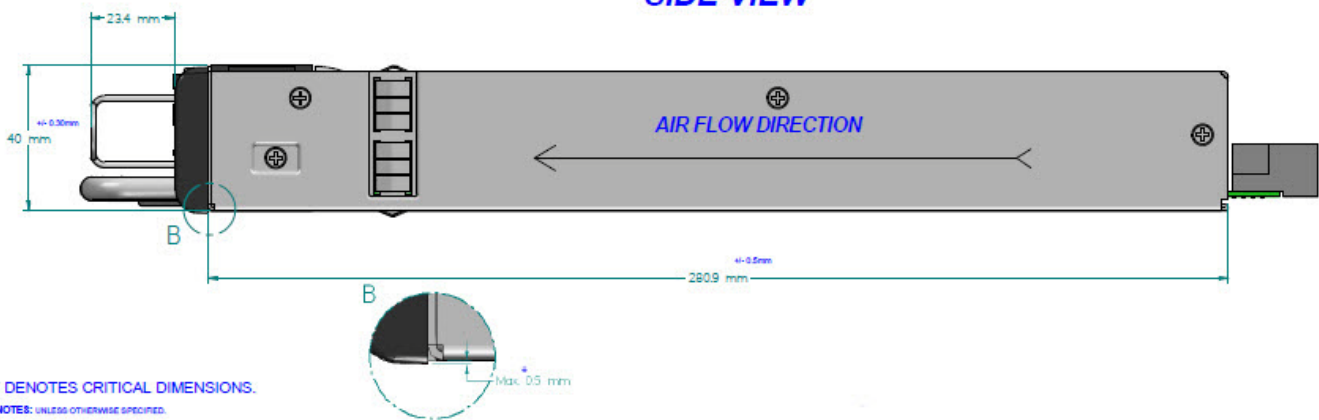

* DENOTES CRITICAL DIMENSIONS.
NOTE: UNLESS OTHERWISE SPECIFIED.

Connector Information

Power Supply:

Input - IEC 320 input (Male) standard line cord connection
Output - P/N FCI 51721-10002406AA or equivalent

Mating Connections:

Input - IEC 320 output (Socket) Standard line cord (15A)
Output - P/N: FCI 51741-10002406CC

Input IEC Connector

Input	Location
Chassis (Safety) Ground	Ground
Line 1 (Line)	L
Line 2 (Neutral)	N

SFP650-12BG AC-DC Front-End Data Sheet

12V Output, 650 Watts

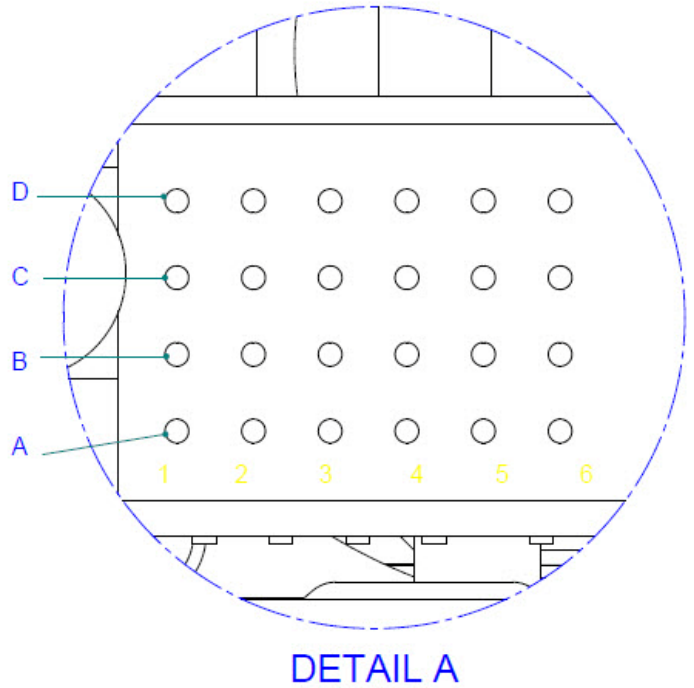
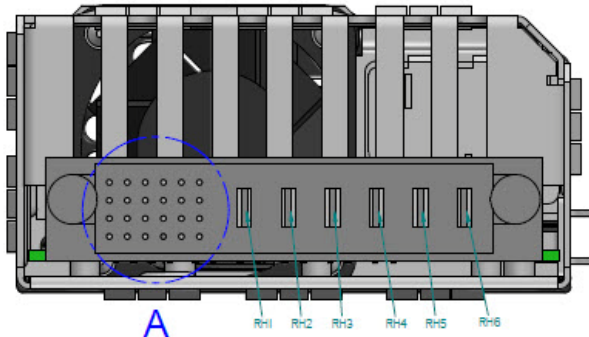

OUTPUT CONNECTOR:

FCI (POWER BLADE)
51721-10002406AC OR EQUIVALENT

WILL MATE WITH SYSTEM BOARD CONNECTOR:

FCI (POWER BLADE) **STRAIGHT IN CONNECTOR**
5174-10002406AA
5174-10002406BA
5174-10002406CB

FCI (POWER BLADE) **RIGHT ANGLE CONNECTOR**
51761-10002406AA
51761-10002406BA
51761-10002406CB

PIN	SIGNAL NAME
Rh1	+12V Return
Rh2	+12V Return
Rh3	+12V Return
Rh4	+12v
Rh5	+12v
Rh6	+12v
A1	PS KILL
A2	+12v Current Share
A3	RETURN
A4	SPARE
A5	PS A0
A6	+3.3V SB
B1	RETURN
B2	Spare
B3	RETURN
B4	+3.3v SB
B5	SDA
B6	PSON/L
C1	RETURN
C2	Tach 1
C3	RETURN
C4	+3.3v SB
C5	SCL
C6	ACOK/L
D1	Present/L
D2	Spare
D3	RETURN
D4	+3.3V SB
D5	Alert/L
D6	PWROK/H

NOTES: UNLESS OTHERWISE SPECIFIED.

SFP650-12BG AC-DC Front-End Data Sheet
12V Output, 650 Watts

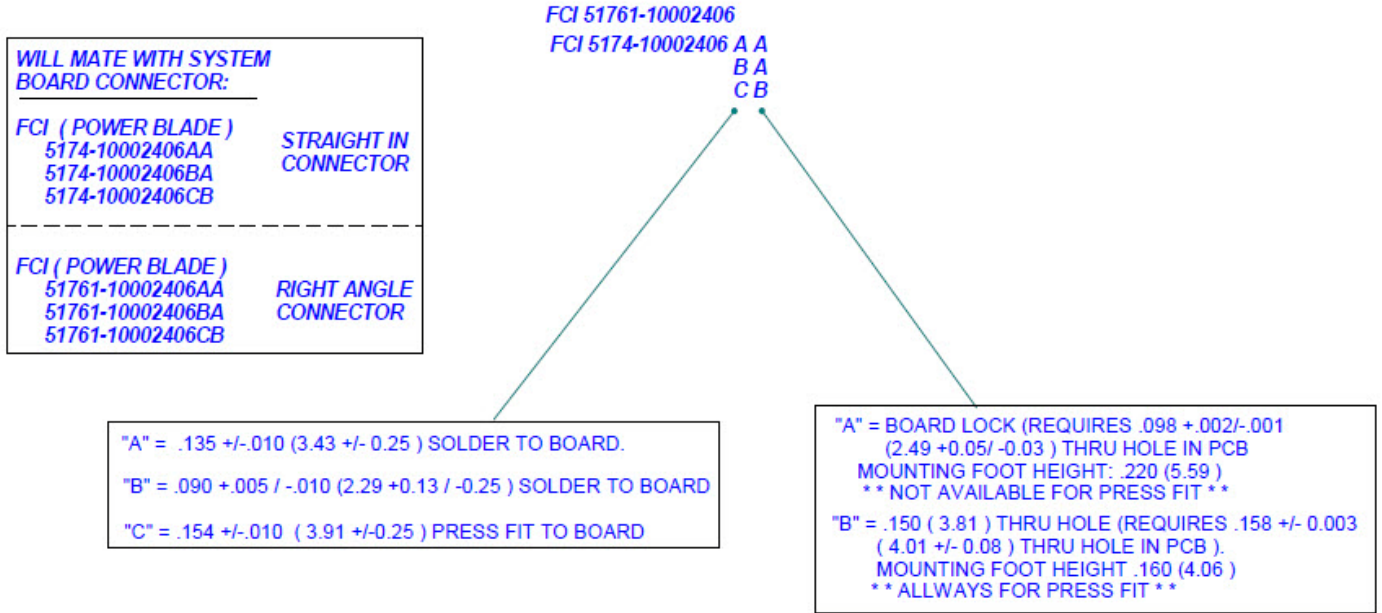

NUCLEAR AND MEDICAL APPLICATIONS - Power-One products are not designed, intended for use in, or authorized for use as critical components in life support systems, equipment used in hazardous environments, or nuclear control systems without the express written consent of the respective divisional president of Power-One, Inc.

TECHNICAL REVISIONS - The appearance of products, including safety agency certifications pictured on labels, may change depending on the date manufactured. Specifications are subject to change without notice.